

INSTRUCTION MANUAL



Eddy Covariance System
CA27 and KH20

Revision: 7/98

Copyright (c) 1994-1998
Campbell Scientific, Inc.

Warranty and Assistance

The **CA27 AND KH20** are warranted by CAMPBELL SCIENTIFIC, INC. to be free from defects in materials and workmanship under normal use and service for twelve (12) months from date of shipment unless specified otherwise. Batteries have no warranty. CAMPBELL SCIENTIFIC, INC.'s obligation under this warranty is limited to repairing or replacing (at CAMPBELL SCIENTIFIC, INC.'s option) defective products. The customer shall assume all costs of removing, reinstalling, and shipping defective products to CAMPBELL SCIENTIFIC, INC. CAMPBELL SCIENTIFIC, INC. will return such products by surface carrier prepaid. This warranty shall not apply to any CAMPBELL SCIENTIFIC, INC. products which have been subjected to modification, misuse, neglect, accidents of nature, or shipping damage. This warranty is in lieu of all other warranties, expressed or implied, including warranties of merchantability or fitness for a particular purpose. CAMPBELL SCIENTIFIC, INC. is not liable for special, indirect, incidental, or consequential damages.

Products may not be returned without prior authorization. The following contact information is for US and International customers residing in countries served by Campbell Scientific, Inc. directly. Affiliate companies handle repairs for customers within their territories. Please visit www.campbellsci.com to determine which Campbell Scientific company serves your country. To obtain a Returned Materials Authorization (RMA), contact CAMPBELL SCIENTIFIC, INC., phone (435) 753-2342. After an applications engineer determines the nature of the problem, an RMA number will be issued. Please write this number clearly on the outside of the shipping container. CAMPBELL SCIENTIFIC's shipping address is:

CAMPBELL SCIENTIFIC, INC.
RMA# _____
815 West 1800 North
Logan, Utah 84321-1784

CAMPBELL SCIENTIFIC, INC. does not accept collect calls.

Warranty for KH20 source and detector tubes

This warranty applies to the KH20 source and detector tubes only and is in lieu of CAMPBELL SCIENTIFIC INC.'s standard warranty policy. The source and detector tubes are warranted by CAMPBELL SCIENTIFIC, INC. to be free from defect in materials and workmanship under normal use and service for three (3) months from the date of shipment.

EDDY COVARIANCE SYSTEM TABLE OF CONTENTS

PDF viewers note: These page numbers refer to the printed version of this document. Use the Adobe Acrobat® bookmarks tab for links to specific sections.

		PAGE
1. SYSTEM OVERVIEW		
1.1	Review of Theory	1-1
1.2	System Description	1-1
1.3	System Limitations	1-2
2. STATION INSTALLATION		
2.1	Sensor Height	2-2
2.2	Mounting.....	2-2
2.3	KH2O Calibrations	2-3
2.4	Finding Water Vapor Density	2-3
2.5	Soil Thermocouples, Heat Flux Plates, and CS615.....	2-4
2.6	Wiring.....	2-5
2.7	Power	2-6
2.8	Routine Maintenance	2-7
3.	SAMPLE 21X PROGRAM	3-1
4. CALCULATING FLUXES USING SPLIT		
4.1	Flux Calculations.....	4-1
4.2	Example Split Programs.....	4-1
5. TROUBLESHOOTING		
5.1	Symptoms, Problems, and Solutions	5-1
APPENDIXES		
A. USING A KRYPTON HYGROMETER TO MAKE WATER VAPOR MEASUREMENTS		
A.1	Water Vapor Fluxes	A-1
A.2	Variance of Water Vapor Density.....	A-2
B.	REMOVING THE TRANSDUCERS ON THE CA27	B-1
C.	ADJUSTING THE CA27 ZERO OFFSET	C-1
D.	LIST OF VARIABLES AND CONSTANTS	D-1
E.	REFERENCES	E-1

SECTION 1. SYSTEM OVERVIEW

1.1 REVIEW OF THEORY

The surface layer (Figure 1.1-1) is comprised of approximately the lower 10% of the atmospheric boundary layer (ABL). The fluxes of water vapor and heat within this layer are nearly constant with height when the following criteria are met: the surface has approximate horizontal homogeneity; and the relationship $z/h \ll 1 \ll z/z_{om}$ is true, where z_{sfc} is the height of the surface layer, h is the height of the ABL, and z_{om} is the roughness length of momentum. When the above conditions are met, the flux of water vapor and heat, within the surface layer, may be written as:

$$LE = L_v \overline{w' \rho'_v} \quad (1)$$

$$H = \rho_a C_p \overline{w' T'} \quad (2)$$

where LE is the latent heat flux, L_v is the latent heat of vaporization, w' is the instantaneous deviation of vertical wind speed from the mean, ρ'_v is the instantaneous deviation of the water vapor density from the mean, H is the sensible heat flux, ρ_a is the density of air, C_p is the heat capacity of air at a constant pressure, and T' is the instantaneous deviation of air temperature from the mean (Stull, 1988).

The quantities $\overline{w' T'}$ and $\overline{w' \rho'_v}$ are the covariances between vertical wind speed and temperature, and vertical wind speed and vapor density. These quantities can be readily calculated on-line by the datalogger.

The eddy covariance system directly measures latent and sensible heat flux. If net radiation and soil heat flux are also measured, energy balance closure may be examined using the surface energy balance equation:

$$R_n - G = H + LE \quad (3)$$

where R_n is the net radiation and G is the total soil heat flux. H , LE , and G are defined as positive away from the surface and R_n is positive toward the surface.

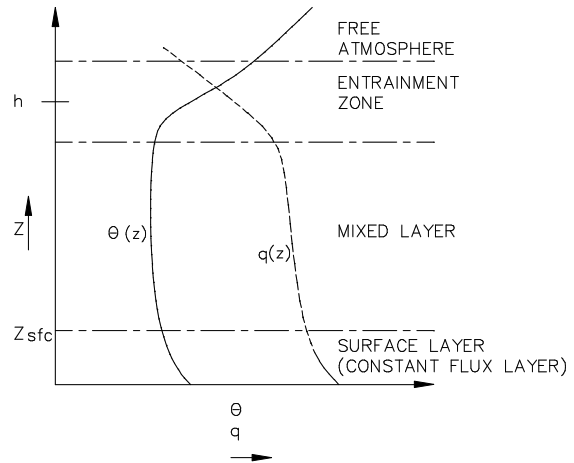

FIGURE 1.1-1. Ideal Vertical Profiles of Virtual Potential Temperature and Specific Humidity Depicting All the Layers of the Atmospheric Boundary Layer.

1.2 SYSTEM DESCRIPTION

1.2.1 SURFACE FLUX SENSORS

The eddy covariance system consists of three sensors that measure the fluctuations in vertical wind speed, air temperature, and water vapor density. The CA27 is a one dimensional sonic anemometer with a fine wire thermocouple (127). The CA27 has a path length of 10 cm and frequency response of 40 Hz. The 127 is a 12.7 μm fine wire thermocouple with a frequency response of greater than 30 Hz. The small size and symmetric construction of the 127 thermocouple junction minimizes radiation loading (Tanner, 1979), thus it is not necessary to shield the 127.

The KH20 is an ultraviolet krypton hygrometer (Campbell and Tanner, 1985) which is similar in principle to the Lyman-alpha hygrometer (Buck, 1976), except that the source tube contains krypton gas. The KH20 has a frequency response of 100 Hz.

1.2.1.1 Additional Required Measurements

Ambient air temperature and humidity must be measured. This information is used to make corrections to the water vapor measurements and calculate air density.

SECTION 1. SYSTEM OVERVIEW

Wind direction must also be measured. The wind direction is used to identify periods when the mean wind was blowing over the back of the eddy covariance sensors. Flux data from these periods should not be used because of potential flow distortions caused by the body and mounts of the CA27 and KH20. A 75 degree sector behind the sonic and hygrometer exists where flow distortions may occur.

1.2.1.2 Optional Measurements

When analyzing the surface flux data, it is often useful to know the horizontal wind speed, along with the wind direction. An estimate of friction velocity and roughness length can be found from the standard deviation of the vertical wind speed and the mean horizontal wind speed, during neutral conditions, e.g., $H \approx 0$ (Panofsky and Dutton, pp. 160, 1984).

If net radiation and soil heat flux are measured over the same period as the surface fluxes, a check of energy balance closure may be made. Net radiation is measured with a net radiometer. Soil heat flux is measured by burying soil heat flux plates at 8 cm. The average temperature change of the soil layer above the plates is measured with four parallel thermocouples. The soil heat storage term is then found by multiplying the change in soil temperature over the averaging period by the total soil heat capacity. The heat flux at the surface is the sum of the measured heat flux at 8 cm and the storage term. A measure of soil moisture is required to find the total soil heat capacity. Soil moisture can be found with the CS615 water content reflectometer or by sampling.

1.2.2 POWER SUPPLY

The current requirements of a typical eddy covariance station are given in Table 1.2-1. A user-supplied 70 Amp hour battery will run the system continuously for approximately two months.

TABLE 1.2-1. Power Requirements for a Typical Eddy Covariance Station

<u>Sensor</u>	<u>Current at 12 VDC unregulated</u>
CA27	7 - 10 mA
KH20	10 - 20 mA
21X	<25 mA
HMP35C	<5 mA

1.3 SYSTEM LIMITATIONS

1.3.1 RAIN

The CA27 uses unsealed transducers. Water damages the transducers; protect the transducers from rain and irrigation systems.

The 127 fine wire thermocouple junction is extremely fragile. It may break if struck by airborne debris, insects, or rain. Handle the 127 probes with care. Always store the 127 in a 127/ENC enclosure when not in use. Each CA27 should have at least two 127s to minimize system downtime due to a broken fine wire thermocouple.

The seals on the hygrometer can be damaged by prolonged exposure to extreme moisture, e.g., rain. To avoid damage to the seals, protect the hygrometer from rain.

In summary, do not allow the CA27, 127, and KH20 to get wet.

1.3.2 SYSTEM SHUTDOWN

The eddy covariance system can be easily protected from inclement weather with a plastic bag. To avoid collecting meaningless data do the following:

- Set the execution interval to zero in the table where the eddy covariance sensors are being measured.
- Remove the 127 and return it to a 127/ENC enclosure.
- Disconnect the power to the sonic and hygrometer (to conserve battery power and extend the life of the hygrometer tubes).
- Cover the heads of the sonic and hygrometer with a plastic bag.

1.3.3 NO ABSOLUTE REFERENCE

The CA27 zero offset drifts with ambient air temperature. The zero offset drift does not effect the flux measurements, since only the fluctuation about some mean are of interest. This drift does, however, preclude the measurement of the mean vertical wind speed.

The 127 does not measure absolute temperature, instead the 127 is referenced to the unknown temperature of the sonic base. Thus, the output of the 127 is the difference between the ambient air temperature and the temperature of the sonic base. The reference junction (CA27 base) has a thermal time constant of approximately 20 minutes. To extend the thermal time constant of the base, insulate it with hot water pipe insulation. Referencing the 127 to the sonic base does not limit the ability of the 127 to measure temperature fluctuations.

The window on the source tube of the hygrometer is prone to scaling. This scaling is caused by disassociation of atmospheric constituents by the ultraviolet photons (Campbell and Tanner, 1985). The rate of scaling is a function of the atmospheric humidity. In high humidity environments, scaling can occur within a few hours. This scaling attenuates the signal and can cause shifts in the calibration curve. However, the scaling over a typical flux averaging period is small. Thus, water vapor fluctuation measurements can still be made with the hygrometer. The effects of the scaling can be easily reversed by wiping the windows with a moist swab.

SECTION 2. STATION INSTALLATION

Figure 2-1 depicts a typical eddy covariance station that measures the latent and sensible heat flux, ambient air temperature and humidity, wind speed and direction, net radiation, soil heat flux, and soil temperature.

Point the eddy covariance sensors into the prevailing wind and the net radiometer to the south. The net radiometer must be mounted far enough from any obstructions so that it is never shaded. Its field of view should be representative of the surface where the flux measurements are being made. The net radiometer can be mounted on a user-supplied stake or a CM6/CM10 tripod. The Tripod Weather Station installation manual contains detailed instructions on installing the tripod and the meteorological sensors.

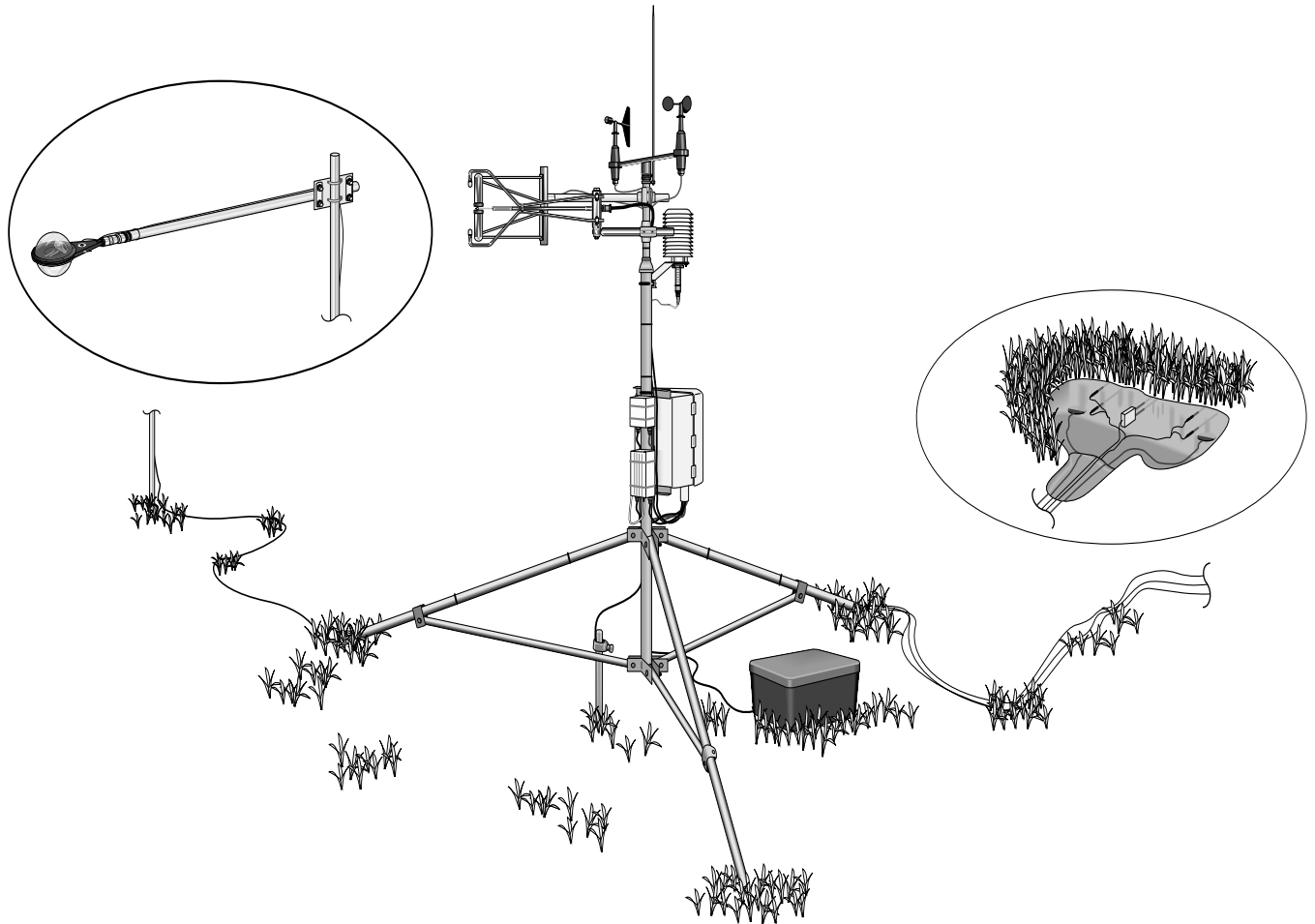

FIGURE 2-1. Eddy Covariance Station

SECTION 2. STATION INSTALLATION

2.1 SENSOR HEIGHT

The eddy covariance sensors must be mounted at some height that ensures that the measurements are being made within the local surface layer. The local surface layer grows at a rate of approximately 1 vertical meter per 100 horizontal meters. Thus, a height to fetch (horizontal distance traveled) ratio of 1:100 can be used as a rough rule of thumb for determining the measurement height.

The following references discuss fetch requirements in detail: Brutsaert (1986); Dyer and Pruitt (1962); Gash (1986); Schuepp, et al. (1990); and Shuttleworth (1992). The fetch should be homogenous and flat, and no abrupt changes in vegetation height should exist (Tanner, 1988). Consider two adjacent fields, the first planted with 1 m tall corn and the second with 0.5 m soybean. Eddy covariance sensors mounted at 2 m above the corn field should have a minimum of 200 m of fetch in all the directions that the data is of interest, particularly between the eddy covariance sensors and the interface between the corn and soybean field.

2.2 MOUNTING

The CA27 and KH20 are shipped with a 0.75 inch by 0.75 inch NU-Rail (P/N 1017). The NU-Rail is used to attach the horizontal mounting arm to a 0.75 inch pipe vertical mast. The top section of a CM6 tripod (Figure 2-1) can be used as a horizontal cross arm mount. It can be replaced with a longer threaded pipe if necessary.

The CM6 leg separation can be adjusted to give a measurement height of 1.1 m to 2.0 m. If the desired measurement height is outside this range, a CM10 or other user-supplied mounting hardware will be required.

The CA27 must be mounted perpendicular to the surface. This is done so that no horizontal component of the wind is measured. In most applications the surface is perpendicular to gravity, thus the bubble level on the top of the CA27 can be used to level the sensor.

Mount the KH20 next to the CA27 with a separation of 10 cm. The hygrometer should be set back from the anemometer to minimize flow distortions. Try to keep the hygrometer tubes as far as possible from the fine wire thermocouple. This is done to avoid measuring temperature fluctuations caused by radiation loading of the hygrometer tubes. Figure 2.2-1 depicts one possible mounting configuration.

Mount the KH20 so that the source tube (the longer of the two tubes) is on top. Center the path of the KH20 around the height of the fine wire thermocouple on the CA27.

To mount the 127, place the 127 on the probe arm located between the transducer arms. Gently press and rotate the 127 until it slips into place. To remove the 127, pull it horizontally away from the CA27 base.

CAUTION: Do not twist the 127 once it is seated on the mounting arm.

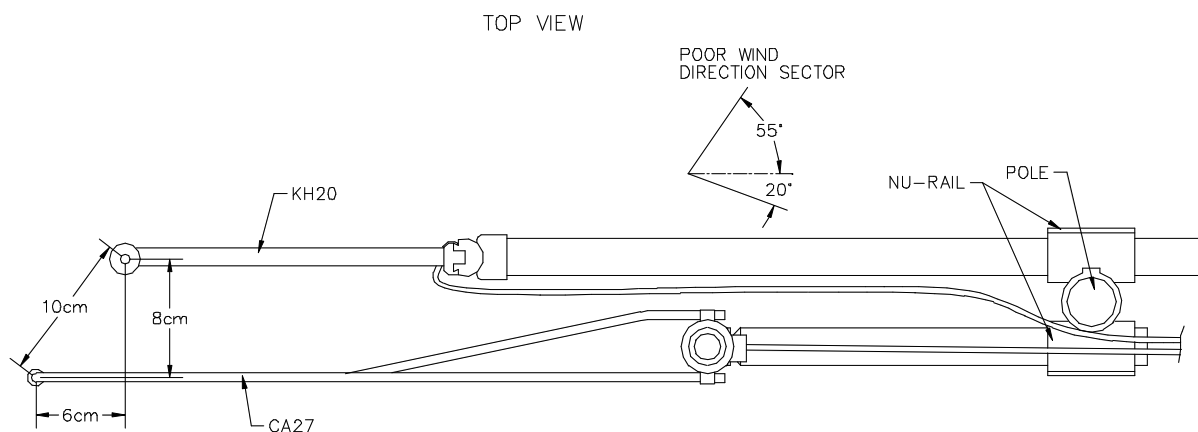

FIGURE 2.2-1. Top and Side View of the CA27 and KH20

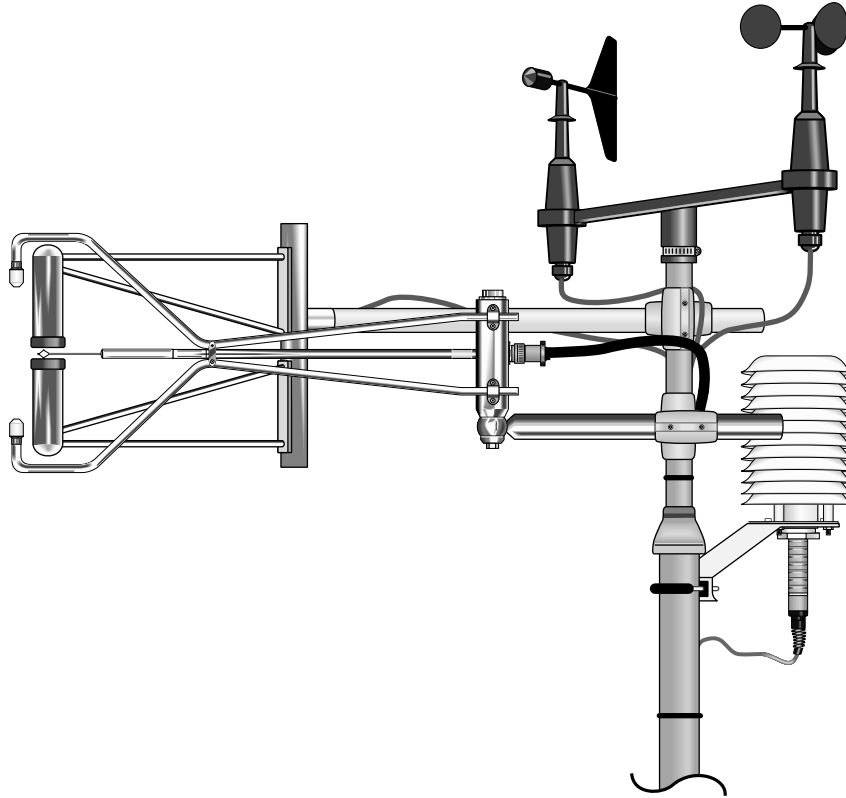

FIGURE 2.2-2 CA27, KH20, HMP35C, and Wind Sentry Set On a CM6 Tripod

2.3 KH20 CALIBRATIONS

Each KH20 is calibrated over three different vapor ranges. The vapor ranges are summarized in Table 2.3-1. This calibration may have been done under the following conditions: windows scaled and clean, and at sea level or 4500 ft (Logan, UT, 1372 m).

TABLE 2.3-1. KH20 Vapor Ranges

Range	$g\ m^{-3}$
Full	2 - 19
Dry	2 - 9.5
Wet	8.25 - 19

Before the KH20 is deployed in the field the following decisions must be made:

- Which calibrated elevation is most appropriate for the site?
- Will the windows be allowed to scale?
- What vapor range is appropriate for the site?

Once those decisions are made, then the appropriate $-k_w$ can be chosen from the KH20 calibration sheet. The path length (x) of the KH20 is also given on each calibration sheet.

The Wet and Dry ranges will provide higher resolution of vapor density fluctuations than the Full Range. However, If the vapor range is unknown or the vapor density is on the border between Wet and Dry, then the Full range should be used.

2.4 FINDING WATER VAPOR DENSITY

The ambient air temperature and relative humidity are needed to calculate the vapor density. The vapor density can then be used to determine the correct vapor range to use on the KH20.

From the ambient air temperature, the saturation vapor pressure can be found using the following sixth order polynomial:

$$e_s = 0.1 \times (a_0 + a_1T + a_2T^2 + a_3T^3 + a_4T^4 + a_5T^5 + a_6T^6) \tag{4}$$

where e_s is the saturation vapor pressure (kPa), T is the ambient air temperature (K) (Lowe, 1977). The coefficients for Eq. (4) are given in Table 2.4-1.

SECTION 2. STATION INSTALLATION

TABLE 2.4-1 Polynomial Coefficients

$a_0 = 6984.505294$
$a_1 = -188.9039310$
$a_2 = 2.133357675$
$a_3 = -1.288580973 \times 10^{-2}$
$a_4 = 4.393587233 \times 10^{-5}$
$a_5 = -8.023923082 \times 10^{-8}$
$a_6 = 6.136820929 \times 10^{-11}$

Similar algorithms can be found in Goff and Gratch (1946) and Weiss (1977).

The vapor pressure is then given by the equation below.

$$e = 0.01 \times RH \times e_s \quad (5)$$

The vapor pressure (e) is in kPa and RH is the relative percent humidity. Finally, the water vapor density is found with the following:

$$\rho_v = \frac{e \cdot 10^6}{TR_v} \quad (6)$$

where ρ_v is the vapor density (g m^{-3}), R_v is the gas constant for water vapor ($461.5 \text{ J K}^{-1} \text{ kg}^{-1}$) (Stull, 1988).

2.5 SOIL THERMOCOUPLES, HEAT FLUX PLATES, AND CS615

The soil thermocouples, heat flux plates, and the water content reflectometer are typically installed as in Figure 2.5-1. The TCAV parallels four thermocouples together to provide the average temperature (see Figure 2.5-2). It is constructed so that two thermocouples can be used to obtain the average temperature of the soil layer above one heat flux plate and the other two above a second plate. The thermocouple pairs may be up to two meters apart.

The location of the two heat flux plates and thermocouples should be chosen to be representative of the area under study. If the ground cover is extremely varied, it may be necessary to have additional sensors to provide a valid average.

Use a small shovel to make a vertical slice in the soil and excavate the soil to one side of the slice. Keep this soil intact so that it may be replaced with minimal disruption.

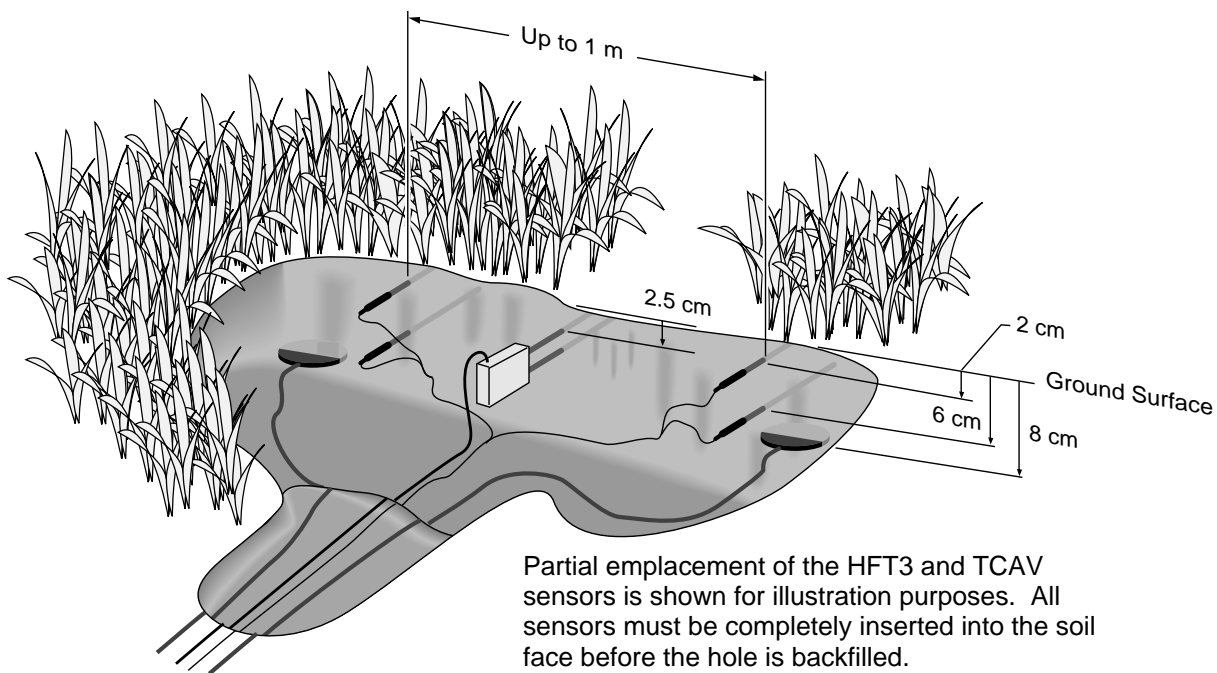

FIGURE 2.5-1. Placement of Thermocouples and Heat Flux Plates

SECTION 2. STATION INSTALLATION

The sensors are installed in the undisturbed face of the hole. Measure the sensor depths from the top of the hole. Make a horizontal cut, with a knife, into the undisturbed face of the hole and insert the heat flux plates into the horizontal cut. Press the stainless steel tubes of the TCAVs above the heat flux plates as shown in Figure 2.5-1. Be sure to insert the tube horizontally. When removing the thermocouples, grip the tubing, not the thermocouple wire.

Install the CS615 as shown in Figure 2.5-1. See the CS615 manual (Section 5) for detailed installation instructions.

Never run the leads directly to the surface. Rather, bury the sensor leads a short distance

back from the hole to minimize thermal conduction on the lead wires. Replace the excavated soil back to its original position.

Finally, wrap the end of the thermocouple wire around the 21X base at least twice before wiring them into the terminal strip. This will minimize thermal conduction into the terminal strip. After all the connections are made, replace the terminal strip cover.

2.6 WIRING

The CA27 and KH20 are shipped with 25 ft standard lead lengths. Table 2.6-1 lists the connections for the CA27 and the KH20.

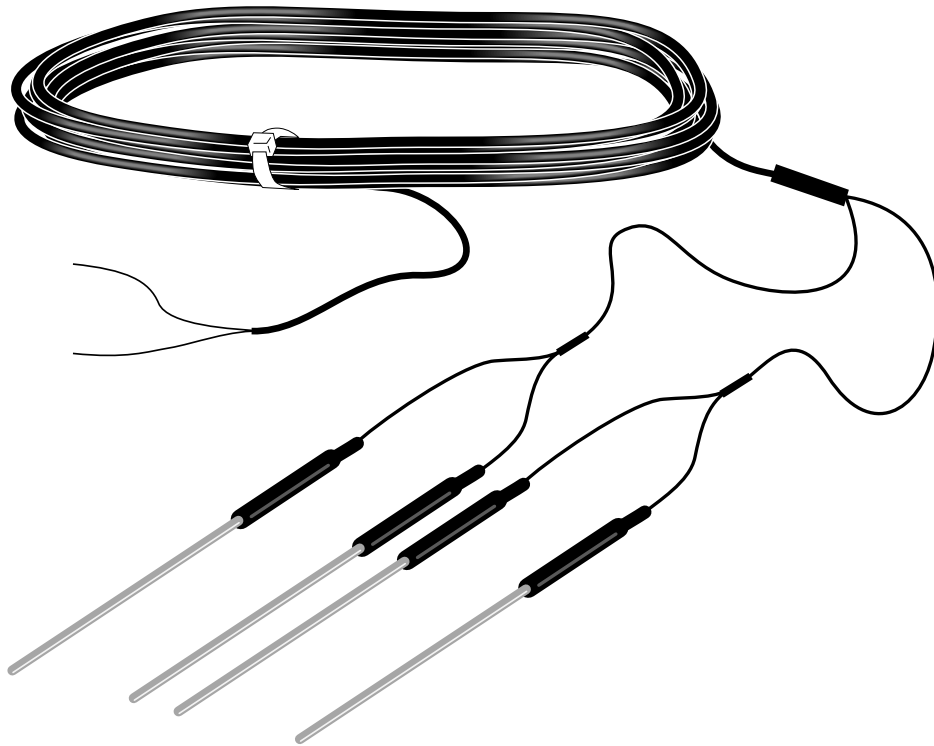

FIGURE 2.5-2. TCAV Spatial Averaging Thermocouple Probe

SECTION 2. STATION INSTALLATION

TABLE 2.6-1. CA27 and KH20 Sensor Lead Color Assignments

Sensor	Color
CA27 Wind +	Green
CA27 Wind -	Black
CA27 Shield	Clear
CA27 Temperature +	White
CA27 Temperature -	Black (same as Wind-)
CA27 +12 V	Red
CA27 Power Gnd	Black of Red and Black
KH20 Water Vapor +	White
KH20 Water Vapor -	Black
KH20 Shield	Clear
KH20 +12 V	Red
KH20 Power Gnd	Black of Red and Black

Tables 2.6-2 and 2.7-1 list the connections to the 21X for the example program in Section 3. The following sensors are measured in the example:

- CA27 (vertical wind speed and temperature fluctuations)
- KH20 (water vapor density fluctuations)
- Q7 (net radiation)
- HFT3 (soil heat flux)
- TCAV (soil temperature)
- HMP35C (ambient air temperature and relative humidity)
- 03001 (wind speed and direction)
- CS615 (soil moisture)

TABLE 2.6-2. 21X/Sensor Connections for Example Program

Channel	Sensor	Color
1H	CA27 + (wind)	Green
1L	CA27 - (wind/temp)	Black
GND	Shield	Clear
2H	CA27 + (temp)	White
2L	jumper to 1L	
GND		
3H	KH20 + (vapor)	White
3L	KH20 - (vapor)	Black
GND	Shield	Clear
4H	TCAV + (soil temp)	Purple
4L	TCAV - (soil temp)	Red
GND		

5H	HMP35C (air temp)	Orange
5L	HMP35C (humidity)	Green
GND	Ground/Shield	White/Clear
6H	HTF1 #1 (soil heat flux)	Black
6L	HTF1 #2 (soil heat flux)	Black
GND	Ground/Shield	White/Clear
	Ground/Shield	White/Clear
7H	Not used	
7L	03001 (wind direction)	Red
GND	03001 Ground/Shield	White/Clear
8H	Q7 + (net radiation)	Red
8L	Q7 - (net radiation)	Black
GND	Shield	Clear
1EX	HMP35C (temp)	Black
2EX	03001 (wind direction)	Black
1C	HMP35C (turn unit on)	Yellow
GND	HMP35C (power ground)	Purple
2C	CS615 (turn unit on)	Orange
1P	03001 (wind speed)	Black
GND	Ground/Shield	White/Clear
2P	CS615 (soil water content)	Green
GND	Ground/Shield	Black/Clear
+12	HMP35C	Red
+12	CS615	Red
GND	To the common earth ground	

2.7 POWER

The CA27 and KH20 are powered by an external battery. A user-supplied 70 Ahr deep cycle RV battery will run the system for approximately two months. The CA27 and KH20 power cables are connected directly to the battery terminals. Disconnect the power cables when the system is not collecting data, e.g. during a rain shower.

Power the 21X from the external battery. Table 2.7-1 summarizes the power connections.

NOTE: If the 21X is powered by an external battery, it must have a blocking diode in the supply line from its internal batteries to prevent reverse charging of the alkaline cells by the external battery. This diode has been standard on all 21Xs shipped since January 19, 1987. If an earlier 21X is being used, either add the diode (contact Campbell Scientific for details) or turn off the 21X power switch while the external battery is connected.

Be sure the 21X has a good earth ground, to protect against primary and secondary lightning strikes. The purpose of an earth ground is to minimize damage to the system by providing a low resistance path around the system to a point of low potential. Campbell Scientific recommends that all dataloggers in the field be earth grounded. All components of the system (datalogger, sensors, external power supplies, mounts, housing, etc.) should be referenced to one common earth ground.

TABLE 2.7-1. External Battery Connections for Example Program

<u>Terminal</u>	<u>Sensor</u>	<u>Color</u>
Pos (+)	CA27 (power)	Red
	KH20 (power)	Red
	21X (+12, see note)	User Supplied
Neg (-)	CA27 (power)	Black
	KH20 (power)	Black
	21X (ground)	User Supplied

2.8 ROUTINE MAINTENANCE

Check the 127 on a daily basis. If the 127 is broken, replace it.

Inspect the 127 for spider webs. Carefully blow away any spider webs with a can of compressed air. Do not put the thermocouple junction directly in the air stream from the can because the junction may break. Direct the air stream to the side of the junction.

If the system is running “windows clean”, clean the windows with a moistened swab. Set flag 1 high to disable averaging. Use only distilled water to moisten the swab. With a fresh swab, dry the windows after cleaning. Set flag 1 low to resume averaging.

CAUTION: Never look directly into the KH20 source tube (the larger of the two tubes).

Check the net radiometer domes for dirt and debris. A camel’s hair brush, with bellows for blowing off dust particles such as those used in cleaning photographic negatives, can be used without fear of scratching the domes.

SECTION 3. SAMPLE 21X PROGRAM

This section provides a sample program that may be used to measure the eddy covariance sensors and the auxiliary sensors. The CA27, 127, and KH20 are measured in Table 1 at 5 Hz. The meteorological sensors and the energy balance sensors are measured in Table 2 at 0.5 Hz. The meteorological sensors include wind speed, wind direction, air temperature, and vapor pressure. The energy balance sensors include net radiation, soil heat flux soil temperature, soil water content, and change in soil temperature. Note that even if this exact installation is used, the correct multipliers must be entered for the net radiometer and soil heat flux plate.

The execution interval in Table 1 may be changed to 0.1 (10 Hz). For most flux studies the increased sample rate does not add any significant statistical information about the turbulent fluxes. It does, however, increase the current drain of the datalogger and cause Table 1 to overrun every ten minutes when the subinterval averages are calculated. If the execution interval is changed to 0.1, the seventh parameter in the twelfth instruction (P62) must be changed to 6000.

To conserve battery power and extend the life of the krypton hygrometer tubes, disconnect the CA27 and KH20 from the battery when measurements are not being made, e.g., during a rain shower. During a rain shower or other inclement weather, shut down and cover the eddy correction system with plastic bags (see Section 1.3.1 for details).

Set flag 1 high to disable averaging while cleaning the KH20 windows and performing other station maintenance. Set flag 1 low to resume averaging.

```

;{21X}
;
;c:\dl\leclecsep96.csi
;5 September 1996
;

```

*Table 1 Program

01:	0.2	Execution Interval (seconds)
01: If Flag/Port (P91)		
1:	22	Do if Flag 2 is Low
2:	2	Call Subroutine 2
02: Volt (Diff) (P2)		
1:	3	Reps
2:	15	5000 mV Fast Range
3:	1	In Chan
4:	1	Loc [w]
5:	1	Mult
6:	0	Offset
03: Z=X*F (P37)		
1:	1	X Loc [w]
2:	.001	F
3:	1	Z Loc [w]
04: Z=X*F (P37)		
1:	2	X Loc [T]
2:	.004	F
3:	2	Z Loc [T]

;Move new signal before natural log.

SECTION 3. SAMPLE 21X PROGRAM

```
;  
05:  Z=X (P31)  
     1:    3      X Loc [ InVh  ]  
     2:    4      Z Loc [ Vh    ]  
  
;Copy KH20 output.  
;  
06:  Z=X (P31)  
     1:    3      X Loc [ InVh  ]  
     2:    5      Z Loc [ Vh_mV  ]  
  
07:  Z=LN(X) (P40)  
     1:    3      X Loc [ InVh  ]  
     2:    3      Z Loc [ InVh  ]  
  
;Subtract a constant.  
;  
08:  Z=X-Y (P35)  
     1:    3      X Loc [ InVh  ]  
     2:   23      Y Loc [ InVho  ]  
     3:    3      Z Loc [ InVh  ]  
  
;Subtract a constant.  
;  
09:  Z=X-Y (P35)  
     1:    4      X Loc [ Vh    ]  
     2:   24      Y Loc [ Vho   ]  
     3:    4      Z Loc [ Vh    ]  
  
;Set Flag 1 high while cleaning KH20 windows.  
;  
10:  If Flag/Port (P91)  
     1:   11      Do if Flag 1 is High  
     2:   19      Set Flag 9 High  
  
11:  If time is (P92)  
     1:    0      Minutes into a  
     2:   30      Minute Interval  
     3:   10      Set Output Flag High  
  
;Ten minute subinterval average.  
;10 min/avg period = (3000 smpls/avg period / (5 smpls/sec * 60 sec/min)).  
;  
12:  CV/CR (OSX-0) (P62)  
     1:    4      No. of Input Locations  
     2:    4      No. of Means  
     3:    4      No. of Variances  
     4:    0      No. of Std. Dev.  
     5:    4      No. of Covariance  
     6:    0      No. of Correlations  
     7:  3000     Samples per Average  
     8:    1      First Sample Loc [ w    ]  
     9:   10     Loc [ avg_w    ]
```

```

13:  If Flag/Port (P91)
      1:   10      Do if Output Flag is High (Flag 0)
      2:   30      Then Do

```

```

;(w'T)rhoCp = H
;

```

```

14:  Z=X*Y (P36)
      1:   18      X Loc [ H      ]
      2:   27      Y Loc [ rhoCp  ]
      3:   18      Z Loc [ H      ]

```

```

;[w'(lnVh)]Lv/-xkw = LE
;

```

```

15:  Z=X/Y (P38)
      1:   19      X Loc [ LE      ]
      2:   26      Y Loc [ neg_xkw ]
      3:   19      Z Loc [ LE      ]

```

```

16:  Z=X*Y (P36)
      1:   19      X Loc [ LE      ]
      2:   28      Y Loc [ Lv      ]
      3:   19      Z Loc [ LE      ]

```

```

;Add constant to average.
;

```

```

17:  Z=X+Y (P33)
      1:   12      X Loc [ avg_lnVh ]
      2:   23      Y Loc [ lnVho  ]
      3:   12      Z Loc [ avg_lnVh ]

```

```

;Add constant to average.
;

```

```

18:  Z=X+Y (P33)
      1:   13      X Loc [ avg_Vh  ]
      2:   24      Y Loc [ Vho    ]
      3:   13      Z Loc [ avg_Vh  ]

```

```

;Save new constant.
;

```

```

19:  Z=LN(X) (P40)
      1:   5       X Loc [ Vh_mV  ]
      2:   23      Z Loc [ lnVho  ]

```

```

;Save new constant.
;

```

```

20:  Z=X (P31)
      1:   5       X Loc [ Vh_mV  ]
      2:   24      Z Loc [ Vho    ]

```

```

21:  End (P95)

```

```

22:  If Flag/Port (P91)
      1:   10      Do if Output Flag is High (Flag 0)
      2:   10      Set Output Flag High

```

SECTION 3. SAMPLE 21X PROGRAM

23: Set Active Storage Area (P80)
1: 1 Final Storage
2: 12 Array ID

24: Resolution (P78)
1: 0 low resolution

25: Real Time (P77)
1: 0110 Day,Hour/Minute

26: Resolution (P78)
1: 1 high resolution

27: Sample (P70)
1: 4 Reps
2: 25 Loc [neg_kw]

28: Sample (P70)
1: 10 Reps
2: 10 Loc [avg_w]

29: Sample (P70)
1: 1 Reps
2: 21 Loc [T_InVh_]

30: Serial Out (P96)
1: 30 SM192/SM716/CSM1

*Table 2 Program
01: 2.0 Execution Interval (seconds)

01: If Flag/Port (P91)
1: 23 Do if Flag 3 is Low
2: 3 Call Subroutine 3

02: Temp 107 Probe (P11)
1: 1 Reps
2: 9 In Chan
3: 1 Excite all reps w/Exchan 1
4: 41 Loc [Tair]
5: 1 Mult
6: 0 Offset

03: Volts (SE) (P1)
1: 1 Reps
2: 5 5000 mV Slow Range
3: 10 In Chan
4: 48 Loc [RH_frac]
5: .001 Mult
6: 0 Offset

04: Saturation Vapor Pressure (P56)
1: 41 Temperature Loc [Tair]
2: 42 Loc [e]

SECTION 3. SAMPLE 21X PROGRAM

```

05: Z=X*Y (P36)
   1:  42      X Loc [ e      ]
   2:  48      Y Loc [ RH_frac ]
   3:  42      Z Loc [ e      ]

06: Volts (SE) (P1)
   1:  2      Repts
   2:  2      15 mV Slow Range
   3:  11     In Chan
   4:  43     Loc [ SHF#1  ]
   5:  1      Mult
   6:  0      Offset

;Enter multiplier for SHF#1 (mult#1).
;
07: Z=X*F (P37)
   1:  43      X Loc [ SHF#1  ]
   2: mult#1   F
   3:  43      Z Loc [ SHF#1  ]

;Enter multiplier for SHF#2 (mult#2).
;
08: Z=X*F (P37)
   1:  44      X Loc [ SHF#2  ]
   2: mult#2   F
   3:  44      Z Loc [ SHF#2  ]

09: Volt (Diff) (P2)
   1:  1      Repts
   2:  4      500 mV Slow Range
   3:  8      In Chan
   4:  45     Loc [ Rnet    ]
   5:  1      Mult
   6:  0      Offset

10: IF (X<=>F) (P89)
   1:  45     X Loc [ Rnet    ]
   2:  3      >=
   3:  0      F
   4:  30     Then Do

;Apply positive wind correction to Rnet.
;
11: Do (P86)
   1:  4      Call Subroutine 4

12: Else (P94)

;Apply negative wind correction to Rnet.
;
13: Do (P86)
   1:  5      Call Subroutine 5

14: End (P95)

```

SECTION 3. SAMPLE 21X PROGRAM

```
15: Pulse (P3)
1: 1 Reps
2: 1 Pulse Input Chan
3: 21 Low Level AC, Output Hz
4: 49 Loc [ WndSpd ]
5: .75 Mult
6: .2 Offset

16: IF (X<=>F) (P89)
1: 49 X Loc [ WndSpd ]
2: 1 =
3: .2 F
4: 30 Then Do

17: Z=F (P30)
1: 0 F
2: 49 Z Loc [ WndSpd ]

18: End (P95)

19: AC Half Bridge (P5)
1: 1 Reps
2: 5 5000 mV Slow Range
3: 14 In Chan
4: 2 Excite all reps w/Exchan 2
5: 5000 mV Excitation
6: 50 Loc [ WndDir ]
7: 355 Mult
8: 0 Offset

20: Internal Temperature (P17)
1: 40 Loc [ RefTemp ]

21: Thermocouple Temp (DIFF) (P14)
1: 1 Reps
2: 1 5 mV Slow Range
3: 4 In Chan
4: 2 Type E (Chromel-Constantan)
5: 40 Ref Temp Loc [ RefTemp ]
6: 46 Loc [ Tsoil ]
7: 1 Mult
8: 0 Offset

;Turn on CS615 soil moisture probe
;once every half hour.
;
22: If time is (P92)
1: 14 Minutes into a
2: 30 Minute Interval
3: 14 Set Flag 4 High

23: If Flag/Port (P91)
1: 14 Do if Flag 4 is High
2: 30 Then Do
```

SECTION 3. SAMPLE 21X PROGRAM

```

24: Do (P86)
    1: 42      Set Port 2 High

;Measure CS615 soil moisture probe.
;When the CS615 is off (Flag 4 low),
;Input Locations CS615_ms and soil_wtr
;will not change.
;
25: Pulse (P3)
    1: 1      Reps
    2: 2      Pulse Input Channel
    3: 21     Low Level AC, Output Hz
    4: 52     Loc [ CS615_ms ]
    5: .001   Mult
    6: 0      Offset

26: Z=1/X (P42)
    1: 52     X Loc [ CS615_ms ]
    2: 52     Z Loc [ CS615_ms ]

27: Polynomial (P55)
    1: 1      Reps
    2: 52     X Loc [ CS615_ms ]
    3: 53     F(X) Loc [ soil_wtr ]
    4: -.187  C0
    5: .037   C1
    6: .335   C2
    7: 0      C3
    8: 0      C4
    9: 0      C5

28: End (P95)

;Turn CS615 probe off.
;
29: If time is (P92)
    1: 15     Minutes into a
    2: 30     Minute Interval
    3: 30     Then Do

30: Do (P86)
    1: 24     Set Flag 4 Low

31: Do (P86)
    1: 52     Set Port 2 Low

32: End (P95)

33: If time is (P92)
    1: 0      Minutes into a
    2: 30     Minute Interval
    3: 10     Set Output Flag High

34: Set Active Storage Area (P80)
    1: 3      Input Storage
    2: 46     Array ID or Loc [ Tsoil ]

```

SECTION 3. SAMPLE 21X PROGRAM

```

35: Average (P71)
   1: 1      Reps
   2: 46     Loc [ Tsoil  ]

36: If Flag/Port (P91)
   1: 10     Do if Output Flag is High (Flag 0)
   2: 30     Then Do

37: Z=X-Y (P35)
   1: 46     X Loc [ Tsoil  ]
   2: 51     Y Loc [ Prev_Ts ]
   3: 47     Z Loc [ del_Tsoil ]

38: Z=X (P31)
   1: 46     X Loc [ Tsoil  ]
   2: 51     Z Loc [ Prev_Ts ]

;Apply temperature correction to soil
;moisture data measured by the CS615.
;
39: Z=X+F (P34)
   1: 46     X Loc [ Tsoil  ]
   2: -20    F
   3: 31     Z Loc [ I      ]

40: Polynomial (P55)
   1: 1      Reps
   2: 53     X Loc [ soil_wtr ]
   3: 32     F(X) Loc [ J      ]
   4: -.0346 C0
   5: 1.9    C1
   6: -4.5   C2
   7: 0      C3
   8: 0      C4
   9: 0      C5

41: Z=X*F (P37)
   1: 32     X Loc [ J      ]
   2: .01    F
   3: 32     Z Loc [ J      ]

42: Z=X*Y (P36)
   1: 31     X Loc [ I      ]
   2: 32     Y Loc [ J      ]
   3: 31     Z Loc [ I      ]

43: Z=X-Y (P35)
   1: 53     X Loc [ soil_wtr ]
   2: 31     Y Loc [ I      ]
   3: 54     Z Loc [ soil_w_T ]

44: End (P95)

```

SECTION 3. SAMPLE 21X PROGRAM

45: If Flag/Port (P91)
 1: 10 Do if Output Flag is High (Flag 0)
 2: 10 Set Output Flag High

46: Set Active Storage Area (P80)
 1: 1 Final Storage
 2: 21 Array ID

47: Resolution (P78)
 1: 0 low resolution

48: Real Time (P77)
 1: 0110 Day,Hour/Minute

49: Resolution (P78)
 1: 1 high resolution

50: Average (P71)
 1: 6 Reps
 2: 40 Loc [RefTemp]

51: Sample (P70)
 1: 3 Reps
 2: 46 Loc [Tsoil]

52: Wind Vector (P69)
 1: 1 Reps
 2: 300 Samples per Sub-Interval
 3: 0 S, θu , & $\sigma(\theta u)$ Polar
 4: 49 Wind Speed/East Loc [WndSpd]
 5: 50 Wind Direction/North Loc [WndDir]

53: Sample (P70)
 1: 3 Reps
 2: 52 Loc [CS615_ms]

**Table 3 Subroutines*

01: Beginning of Subroutine (P85)
 1: 2 Subroutine 2

02: Do (P86)
 1: 12 Set Flag 2 High

;Enter -kw for hygrometer
 ;

03: Z=F (P30)
 1: -kw F
 2: 25 Z Loc [neg_kw]

;Enter -xkw for hygrometer
 ;

04: Z=F (P30)
 1: -xkw F
 2: 26 Z Loc [neg_xkw]

SECTION 3. SAMPLE 21X PROGRAM

```
05: Z=F (P30)
    1: 1010      F
    2: 27       Z Loc [ rhoCp  ]

06: Z=F (P30)
    1: 2440     F
    2: 28       Z Loc [ Lv    ]

;Measure constant for first pass.
;
07: Volt (Diff) (P2)
    1: 1        Repts
    2: 15       5000 mV Fast Range
    3: 3        In Chan
    4: 24       Loc [ Vho    ]
    5: 1        Mult
    6: 0        Offset

;Constant for first pass.
;
08: Z=LN(X) (P40)
    1: 24       X Loc [ Vho    ]
    2: 23       Z Loc [ InVho  ]

09: Do (P86)
    1: 10       Set Output Flag High

10: Set Active Storage Area (P80)
    1: 1        Final Storage
    2: 11       Array ID

11: Resolution (P78)
    1: 0        low resolution

12: Real Time (P77)
    1: 0110     Day,Hour/Minute

13: Resolution (P78)
    1: 1        high resolution

14: Sample (P70)
    1: 4        Repts
    2: 25       Loc [ neg_kw  ]

15: End (P95)

16: Beginning of Subroutine (P85)
    1: 3        Subroutine 3

17: Do (P86)
    1: 13       Set Flag 3 High

;Turn on RH portion of the HMP35C.
;
18: Do (P86)
    1: 41       Set Port 1 High
```

```

19:  Internal Temperature (P17)
    1:   40      Loc [ RefTemp ]

;Prev_Ts for first pass.
;
20:  Thermocouple Temp (DIFF) (P14)
    1:   1      Repts
    2:   1      5 mV Slow Range
    3:   4      In Chan
    4:   2      Type E (Chromel-Constantan)
    5:  40      Ref Temp Loc [ RefTemp ]
    6:  51      Loc [ Prev_Ts ]
    7:   1      Mult
    8:   0      Offset

21:  End (P95)

22:  Beginning of Subroutine (P85)
    1:   4      Subroutine 4

23:  Z=X*F (P37)
    1:   49      X Loc [ WndSpd ]
    2:   .2      F
    3:   37      Z Loc [ C ]

24:  Z=X*F (P37)
    1:   37      X Loc [ C ]
    2:   .066    F
    3:   35      Z Loc [ A ]

25:  Z=X+F (P34)
    1:   37      X Loc [ C ]
    2:   .066    F
    3:   36      Z Loc [ B ]

26:  Z=X/Y (P38)
    1:   35      X Loc [ A ]
    2:   36      Y Loc [ B ]
    3:   38      Z Loc [ CorrFact ]

27:  Z=Z+1 (P32)
    1:   38      Z Loc [ CorrFact ]

;Enter the positive multiplier (p.ppp).
;
28:  Z=X*F (P37)
    1:   45      X Loc [ Rnet ]
    2:   p.ppp  F
    3:   45      Z Loc [ Rnet ]

29:  Z=X*Y (P36)
    1:   45      X Loc [ Rnet ]
    2:   38      Y Loc [ CorrFact ]
    3:   45      Z Loc [ Rnet ]

```

SECTION 3. SAMPLE 21X PROGRAM

```

30:  End (P95)

31:  Beginning of Subroutine (P85)
    1:    5      Subroutine 5

32:  Z=X*F (P37)
    1:    49      X Loc [ WndSpd  ]
    2:    .00174 F
    3:    35      Z Loc [ A      ]

33:  Z=X+F (P34)
    1:    35      X Loc [ A      ]
    2:    .99755 F
    3:    38      Z Loc [ CorrFact ]

```

;Enter the negative multiplier (n.nnn).

```

;
34:  Z=X*F (P37)
    1:    45      X Loc [ Rnet   ]
    2:    n.nnn  F
    3:    45      Z Loc [ Rnet   ]

35:  Z=X*Y (P36)
    1:    45      X Loc [ Rnet   ]
    2:    38      Y Loc [ CorrFact ]
    3:    45      Z Loc [ Rnet   ]

```

36: End (P95)

End Program

```

*      A      Mode 10 Memory Allocation
01:    56      Input Location
02:    64      Intermediate Locations

```

-Input Locations-

1 w	15 var_T	29 _____	43 SHF#1
2 T	16 var_InVh	30 _____	44 SHF#2
3 InVh	17 var_Vh	31 _____	45 Rnet
4 Vh	18 H	32 _____	46 Tsoil
5 Vh_mV	19 LE	33 _____	47 del_Tsoil
6 _____	20 w'Vh'	34 _____	48 RH_frac
7 _____	21 T'(InVh)'	35 A	49 WndSpd
8 _____	22 _____	36 B	50 WndDir
9 _____	23 InVho	37 C	51 Prev_Ts
10 avg_w	24 Vho	38 CorrFact	52 _____
11 avg_T	25 -kw	39 _____	53 _____
12 avg_InVh	26 -xkw	40 RefTemp	54 _____
13 avg_Vh	27 rhoCp	41 Tair	55 _____
14 var_w	28 Lv	42 e	56 _____

TABLE 3.1-1. Output from Example Eddy Covariance Program

01:	ID = 11; compile time and constants
02:	DAY
03:	Time(hhmm)
04:	$-k_w$ ($m^3 g^{-1} cm^{-1}$)
05:	$-xk_w$ ($m^3 g^{-1}$)
06:	air density x heat capacity ($W m^{-2} K^{-1} m^{-1} s$)
07:	latent heat of vaporization ($J g^{-1}$)
01:	ID = 12; surface flux data
02:	DAY
03:	Time (hhmm)
04:	$-k_w$ ($m^3 g^{-1} cm^{-1}$)
05:	$-xk_w$ ($m^3 g^{-1}$)
06:	air density x heat capacity ($W m^{-2} K^{-1} m^{-1} s$)
07:	latent heat of vaporization ($J g^{-1}$)
08:	average vertical wind speed ($m s^{-1}$)
09:	average CA27 temperature ($^{\circ}C$)
10:	average natural log of KH20 (unit less)
11:	average voltage from KH20 (mV)
12:	variance of the vertical wind speed ($m s^{-1}$)
13:	variance of the CA27 temperature ($^{\circ}C$)
14:	variance of the natural log of KH20 voltage (unit less)
15:	variance of the voltage from KH20 (mV)
16:	sensible heat flux ($W m^{-2}$)
17:	latent heat flux ($W m^{-2}$)
18:	$T'(\ln V_h)$; used in oxygen correction for variance of water vapor density
01:	ID = 21; meteorological and energy balance data
02:	DAY
03:	Time (hhmm)
04:	average panel temperature ($^{\circ}C$)
05:	average ambient air temperature ($^{\circ}C$)
06:	average vapor pressure (kPa)
07:	average soil heat flux #1 ($W m^{-2}$)
08:	average soil heat flux #2 ($W m^{-2}$)
09:	average net radiation ($W m^{-2}$)
10:	average soil temperature ($^{\circ}C$)
11:	change in soil temperature ($^{\circ}C$)
12:	sample RH (fraction)
13:	average wind speed ($m s^{-1}$)
14:	unit vector wind direction (deg)
15:	standard deviation of wind direction (deg)
16:	CS615 period (msec)
17:	soil water content (fraction)
18:	soil water content corrected for soil temperature (fraction)

SECTION 4. CALCULATING FLUXES USING SPLIT

SPLIT (PC208E software) can be used to apply the air density and oxygen corrections to the measured surface fluxes. This section provides example SPLIT programs to make the necessary calculations on the data produced by the sample datalogger program. All the calculations in ECRAW.PAR and ECFLUX.PAR are explained in Sections 1 and Appendix A.

Two runs through SPLIT are required to combine the data and then apply the corrections. The first run operates on the raw data produced by the datalogger. The parameter file ECRAW.PAR is used to make the first run and produces the file called EC.PRN. The second run is made with the parameter file ECFLUX.PAR. This parameter file corrects the air density and applies the necessary oxygen correction to the data. The output file name is FLUX.PRN. To apply the oxygen correction (OCLE) to the latent heat flux, subtract OCLE from LE (see Eq. 14 and 15). To apply the oxygen correction to the standard deviation of water vapor, add OCSD to STDR.

4.1 FLUX CALCULATIONS

The surface flux data is combined with the energy balance and meteorological data. The SPLIT parameter file that does this is listed in TABLE 4.2-1. The parameter file assumes that the data files from the datalogger were saved on disk under the name EC.DAT. An output data file (EC.PRN) is created that will be used to apply all the necessary corrections.

ECFLUX.PAR uses are described in detail in Section 1 and Appendix A. Appendix D summarizes the variable names and definitions.

In some cases it may be necessary to apply an additional correction to the latent heat flux (Webb et al., 1980). The soil storage term and the heat capacity of soil was found following Hanks and Ashcroft, 1980. Soil water content (W) is measured by the CS615. Bulk density (BD) is unique for each site and must be measured for the site. An estimate for atmosphere pressure (P) must also be entered.

4.2 EXAMPLE SPLIT PROGRAMS

Table 4.2-2 lists the parameter file that is used to apply the corrections. The equations that

TABLE 4.2-1. Split Parameter File to Combine Raw Data

Param file is C:\ECRAW.PAR

Name(s) or input DATA FILE(s):	EC.DAT, EC.DAT
Name of OUTPUT FILE to generate:	EC.PRN
START reading in EC.DAT:	2:3
START reading in:	2:3
STOP reading in EC.DAT:	
STOP reading in:	
COPY from EC.DAT:	1[12] AND 3[30]
COPY from:	1[21] AND 3[30]
SELECT element #(s) in EC.DAT:	2..5,P = 85.,P,6..11,SQRT(12..15),16..18
SELECT element #(s) in:	BD=1330.,W =18,LV=(2500.5-2.359*5), TA=5+273.15,Q=(.622*6)/(P-(6*1.622)), CP=(1.+(.87*Q))*1005.,RD=(P-6)*1000./ (287.04*TA),RV=6*1000./(461.5*TA),RA=RD+ RV,F=SPAAVG(7,8),S=11*.08*BD*(840.+ W*4190.)/1800.,TA,6,9,F,S,12..14,LV,CP,RA
HEADING for report:	RAW EDDY COVARIANCE DATA
HEADINGS for EC.DAT, col # 1:	DAY
column # 2:	TIME
column # 3:	-kw
column # 4:	-xkw
column # 5:	P
column # 6:	rhoCp

SECTION 4. CALCULATING FLUXES USING SPLIT

column # 7:	Lv old
column # 8:	avg w
column # 9:	avg T
column # 10:	avg lnV
column # 11:	avg Vh
column # 12:	std w
column # 13:	std T
column # 14:	std lnV
column # 15:	std Vh
column # 16:	H
column # 17:	LE
column # 18:	T'lnV'
HEADINGS for , col. # 19:	Tair
column # 20:	e
column # 21:	Rn
column # 22:	F
column # 23:	S
column # 24:	ws
column # 25:	wd
column # 26:	sd wd
column # 27:	Lv new
column # 28:	Cp
column # 29:	rho air

TABLE 4.2-2. Split Parameter File to Correct Surface Fluxes for Air Density and Oxygen Absorption

Param file is C:\ECFLUX.PAR

Name(s) or input DATA FILE(s):	EC.PRN
Name of OUTPUT FILE to generate:	FLUX.PRN
START reading in ENC.PRN:	1:2
STOP reading in ENC.PRN:	
COPY from ENC.PRN:	2[30]
SELECT element #(s) in ENC.PRN:	H=16*28*29/6,LE=17*27/7,A=5*1000. *.80674*.0045,OCLE=16*A*27/(3*6*19*19), STDR=14/4,OCSD=SQRT(((2.*A*18/(3*4*19*19))))), 1,2,12,13,STDR,OCSD,H,LE,OCLE,21,22+23,22,23
HEADINGS for ENC.PRN, col # 1:	DAY
column # 2:	TIME
column # 3:	STD w
column # 4:	STD T
column # 5:	STD RHOV
column # 6:	OC SD
column # 7:	H
column # 8:	LE
column # 9:	OC LE
column # 10:	RNET
column # 11:	G
column # 12:	F
column # 13:	S

SECTION 5. TROUBLESHOOTING

This section offers some solutions to common problems. All the locations and data values are based on the example program in Section 3.

5.1 SYMPTOMS, PROBLEMS, AND SOLUTIONS

1. **Symptom:** The temperature is a constant value of 17, with the fractional portion randomly fluctuating.

Problem: The 127 fine wire thermocouple is broken or not installed.

Solution: Replace or install the 127.

2. **Symptom:** Signal response on the 127 is down. Input location 2 data is fluctuating slowly.

Problem: Debris is caught up in the fine wire thermocouple junction, e.g. a spider web.

Solution: Carefully blow away the debris with a can of compressed air. Do not direct the air stream at the thermocouple junction because the junction is extremely fragile. Rather, put the junction on the peripheral of the air stream.

3. **Symptom:** The vertical wind is fluctuating only in the hundredths place. When the transducers are blown on, the CA27 does not respond with reasonable values.

Problem: One or more transducers are missing or the transducer pins have been damaged.

Solution: Replace the transducers, see Appendix B for removal and installation procedures.

4. **Symptom:** Vertical wind speed is a near steady positive or negative value.

Problem: A transducer is shorted. The transducers will short if they are twisted on the mounting arms (see Appendix B for proper removal procedure) or if they become wet. When the transducers are shorted, the CA27 outputs a near constant voltage. If the lower transducer is shortened, the CA27 will output a negative value. If the upper transducer is shorted, the CA12 will output a positive value.

Solution: Allow the transducers several hours to dry. Then check the CA27 zero offset with a

zero velocity anechoic chamber (see Appendix C). After checking the zero offset, check the CA27 by blowing on the lower and upper arms of the CA27. The 21X should measure a negative and positive wind speed respectively.

5. **Symptom:** The vertical wind fluctuations are not equally distributed around zero.

Problem: Zero offset has drifted.

Solution: Send the CA27 back to the factory for adjustment or see Appendix C for the zero offset adjustment procedures.

6. **Symptom:** The krypton hygrometer voltage is -99999.

Problem: This problem occurs in extremely arid environments. The hygrometer is outputting signal greater than 5 Volts to the 21X. The 21X can only measure voltages between ± 5 Volts.

Solution: Send the KH20 back to the factory to have its path length widened or use a voltage divider to reduce in the input signal.

7. **Symptom:** KH20 has power, but it is not outputting a signal. The "blue glow" from the source tube (the larger of the two tubes) is not visible. The glow is only visible under low or no light conditions.

CAUTION: Never look directly into the KH20 source tube (the longer of the two tubes). To see the "blue glow", insert a piece of paper between the tubes, under low light conditions, and look at the paper.

When an Ammeter is placed serially in the power line (positive of Ammeter to positive of battery, negative of Ammeter to positive of KH20, and negative of KH20 to negative of battery), the current drain is not in the range of 10 to 20 mA.

Problem: KH20 tubes have blown out.

Solution: Return the KH20 to have the krypton tubes replaced.

APPENDIX A. USING A KRYPTON HYGROMETER TO MAKE WATER VAPOR MEASUREMENTS

A.1 WATER VAPOR FLUXES

The krypton lamp used in the hygrometer emits a major line at 123.58 nm (line 1) and a minor line at 116.49 nm (line 2). Both of these wavelengths are absorbed by water vapor and oxygen. The equation below describes the hygrometer signal in terms of absorption of both lines by water vapor and oxygen.

$$V_h = V_{o1} \exp(-xk_{w1}\rho_v - xk_{o1}\rho_o) + V_{o2} \exp(-xk_{w2}\rho_v - xk_{o2}\rho_o) \quad (1)$$

where V_h is the signal voltage from the hygrometer, V_{o1} and V_{o2} are the signals with no absorption of lines 1 and 2 respectively, x is the path length of the hygrometer, k_{w1} and k_{w2} are the absorption coefficients for water vapor on lines 1 and 2, k_{o1} and k_{o2} are the absorption coefficients for oxygen, and ρ_v and ρ_o are the densities of water vapor and oxygen.

If $V_{o1} \gg V_{o2}$ and $k_{w1} \sim k_{w2}$, Eq. (1) can be rewritten by approximating the individual absorption of the two lines with a single effective coefficient for either water vapor or oxygen.

$$V_h = V_{o1} \exp(-xk_w\rho_v) \left[\exp(-xk_{o1}\rho_o) + (V_{o2}/V_{o1}) \exp(-xk_{o2}\rho_o) \right] \quad (2)$$

Note that the quantity $(V_{o2}/V_{o1}) \rightarrow 0$, thus the above takes on the form below.

$$V_h = V_o \exp(-xk_w\rho_v) \exp(-xk_o\rho_o) \quad (3)$$

Taking the natural log of Eq. (3) and solving for ρ_v yields Eq. (4).

$$\rho_v = \frac{\ln V_h}{-xk_w} - \frac{\ln V_o}{-xk_w} + \frac{k_o}{-k_w} \rho_o \quad (4)$$

Applying the rules of Reynolds averaging, the covariance between the vertical wind speed and water vapor can be written as Eq. (5).

$$\overline{w'\rho'_v} = \overline{w\rho_v} - \overline{w} \overline{\rho_v} \quad (5)$$

Substituting Eq. (4) into (5) yields the equation below. Note that $\ln V_o$ is a constant.

$$\overline{w'\rho'_v} = \frac{\overline{w(\ln V_h)} - \overline{w} \overline{\ln V_h}}{-xk_w} + \frac{k_o}{-k_w} (\overline{w\rho_o} - \overline{w} \overline{\rho_o}) \quad (6)$$

The first term in Eq. (6) is the water vapor flux and second is the oxygen correction. The density of oxygen is not directly measured. It can, however, be written in terms of measured variables using the ideal gas law. The density of oxygen is given by Eq. (7) below.

$$\rho_o = \frac{PC_oM_o}{RT} \quad (7)$$

where P is atmospheric pressure, T is air temperature, C_o is the concentration of oxygen, M_o is the molecular weight of oxygen, and R is the universal gas constant. Substituting Eq. (7) into Eq. (6) gives the equation below.

$$\overline{w'\rho'_v} = \frac{\overline{w(\ln V_h)} - \overline{w} \overline{\ln V_h}}{-xk_w} + \frac{k_o}{-k_w} \frac{C_oM_oP}{R} \left[\overline{\frac{1}{T}} - \overline{w} \overline{\frac{1}{T}} \right] \quad (8)$$

Using a relationship analogous to Eq. (5), the numerator in the first term and the term within the brackets of Eq. (8) can be rewritten. Note that the atmospheric pressure over a typical flux averaging period is constant, thus pressure can be treated as a constant. Finally, the latent heat flux can be written as follows.

APPENDIX A. KRYPTON HYGROMETER IN WATER VAPOR MEASUREMENTS

$$LE = L_v \frac{\overline{w'(\ln V_h)'}}{-xk_w} + OC_1 \quad (9)$$

Where OC_1 is defined by Eq. (10).

$$OC_1 = L_v \frac{k_o}{-k_w} \frac{C_o M_o P}{R} \overline{w'(T^{-1})'} \quad (10)$$

It would be more convenient if the oxygen correction could be written in terms of the covariance of the vertical wind speed and temperature instead of the inverse of temperature. With that in mind, Eq. (6) can be rewritten to take on the following form.

$$\overline{w'\rho'_v} = \frac{\overline{w'(\ln V_h)'}}{-xk_w} + \frac{k_o}{-k_w} \overline{(w'\rho'_o)} \quad (11)$$

The fluctuations of oxygen (O_2) density are due to pressure and temperature changes. These fluctuations can be approximated using the first derivative.

Differentiating the ideal gas law, Eq. (7), yields the following.

$$\rho'_o = \left[\frac{C_o M_o}{RT} \right] P' - \left[\frac{C_o M_o P}{RT^2} \right] T' \quad (12)$$

The fluctuations in pressure are very small over a typical flux averaging period. Thus, Eq. (12) can be written as follows:

$$\rho'_o = - \left[\frac{C_o M_o P}{RT^2} \right] T' \quad (13)$$

Directly substituting Eq. (13) into Eq. (11) and multiplying by the latent heat of vaporization yields the following.

$$LE = L_v \frac{\overline{w'(\ln V_h)'}}{-xk_w} - OC_{LE} \quad (14)$$

where

$$OC_{LE} = L_v \frac{k_o}{-k_w} \frac{C_o M_o P}{RT^2} \overline{(w'T)'} \quad (15)$$

and T is in Kelvin. Eq. (14) and (15) were used in the example SPLIT programs.

A.2 VARIANCE OF WATER VAPOR DENSITY

The variance of the water vapor density can be written as in Eq. (16).

$$\sigma_{\rho_v}^2 = \frac{\sum (\rho_v - \bar{\rho}_v)^2}{N} = \frac{\sum (\rho'_v)^2}{N} = \overline{(\rho'_v)^2} \quad (16)$$

where ρ_v is the instantaneous water vapor density, $\bar{\rho}_v$ is the average water vapor density, and ρ'_v is the instantaneous fluctuation from the mean. The water vapor density fluctuations can be written as in Eq. (17).

$$\rho'_v = \rho_v - \bar{\rho}_v \quad (17)$$

Substitute Eq. (17) and then (4) into Eq. (16). Expand and collect terms where appropriate.

The final result is Eq. (18), which describes the water vapor fluctuations and the coinciding oxygen correction.

$$\begin{aligned} \overline{(\rho'_v)^2} = & (-xk_w)^{-2} \left\{ \left[\overline{(\ln V_h)'} \right]^2 \right. \\ & + \frac{2xk_o C_o M_o P}{R} \overline{(\ln V_h)' (T^{-1})'} \\ & \left. + \left(\frac{xk_o C_o M_o P}{R} \right)^2 \left[\overline{(T^{-1})'} \right]^2 \right\} \quad (18) \end{aligned}$$

The last two terms in Eq. (18), which are the oxygen corrections, are cumbersome to calculate. They can, however, be rewritten in a simpler approximate form.

Substitute Eq. (7) into (4) and differentiate. This leads to Equation (19) below.

$$\rho'_v = \frac{(\ln V_h)'}{-xk_w} - \frac{k_o}{-k_w} \left[\frac{C_o M_o P}{RT^2} \right] T' \quad (19)$$

APPENDIX A. KRYPTON HYGROMETER IN WATER VAPOR MEASUREMENTS

where T is in Kelvin. Directly substitute Eq. (19) into (16) and ignore the last term with order T^{-4} . This yields Eq. (20).

$$\overline{(\rho'_v)^2} = \frac{\overline{[(\ln V_h)']^2}}{(-xk_w)^2} + OC_{VAR} \quad (20)$$

where OC_{VAR} is defined by Eq. (21).

$$OC_{VAR} = - \left[\frac{2C_o M_o P}{RT^2} \right] \left[\frac{k_o}{x(-k_w)^2} \right] \overline{T'(\ln V_h)'} \quad (21)$$

To find the standard deviation of water vapor, simply take the square root of Eq. (20).

APPENDIX B. REMOVING THE TRANSDUCERS ON THE CA27

Firmly hold the transducer, while loosening the knurled knob. Once the knob is loosened, gently pull the transducer from the arm (see Figure B-1).

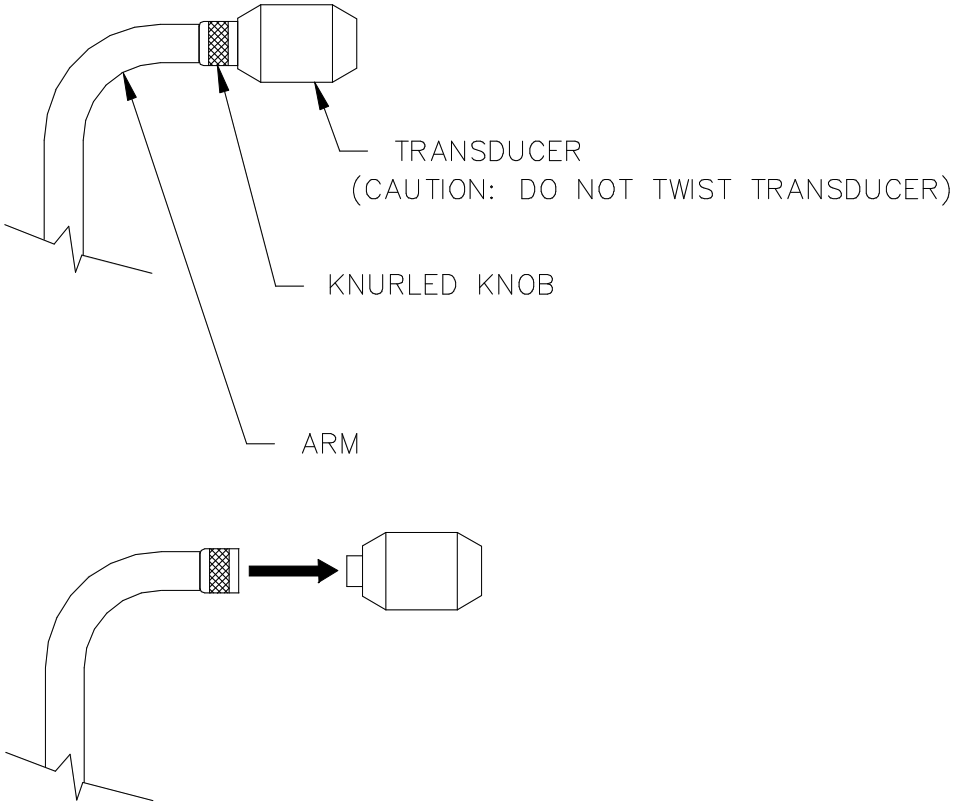

FIGURE B-1. CA27 Transducer and Arm

APPENDIX C. ADJUSTING THE CA27 ZERO OFFSET

A zero velocity anechoic chamber can be made by lining a 5-gallon bucket with foam. The foam lining prevents acoustical reflections from the bucket walls. Two small dish cloths can be used to close off the opening of the bucket.

Place the CA27 head inside the foam-lined bucket. Cover the opening with the dish cloths. Connect the CA27 to the electronics box and the Signal/Power cable to the appropriate channels on the datalogger. Remove the cover of the CA27 electronics box by loosening the four screws to expose the circuit board. Use Instruction 2 with a multiplier of 1 and an offset of 0 to measure the wind speed voltage. Slowly turn the "offset" potentiometer (Figure C-1) until the voltage measured by the 21X is approximately zero. A ± 20 mV fluctuation is normal.

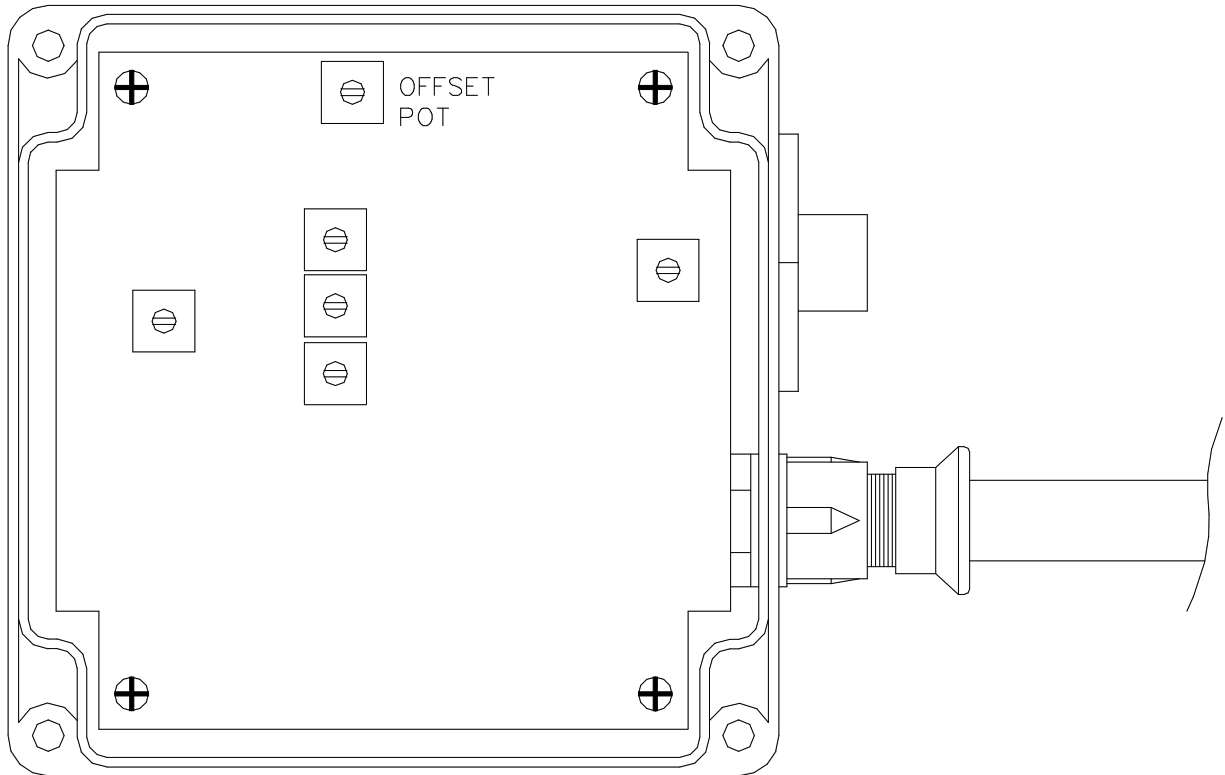

FIGURE C-1. CA27 Electronics Box

APPENDIX D. LIST OF VARIABLES AND CONSTANTS

ρ'_v	g m^{-3}	Instantaneous deviation of water vapor density from mean
ρ_a	g m^{-3}	Density of moist air
ρ_o	g m^{-3}	Density of oxygen
ρ_v	g m^{-3}	Water vapor density
BD	kg m^{-3}	Bulk density of soil
C_o		(0.2095) fraction concentration of oxygen in the atmosphere
C_p	$\text{J kg}^{-1} \text{K}^{-1}$	Heat capacity of moist air
CP	$\text{J kg}^{-1} \text{K}^{-1}$	Heat capacity of moist air
e	kPa	Vapor pressure
e_s	kPa	Saturation vapor pressure
F	W m^{-2}	Soil heat flux measured by the heat flux plates
G	W m^{-2}	Total soil heat flux
h	m	Height of the Atmospheric Boundary Layer
H	W m^{-2}	Sensible heat flux
k_o	$\text{m}^3 \text{g}^{-1} \text{cm}^{-1}$	(0.0045) Absorption coefficient for oxygen
k_{o1}	$\text{m}^3 \text{g}^{-1} \text{cm}^{-1}$	Absorption coefficient for oxygen on line 1
k_{o2}	$\text{m}^3 \text{g}^{-1} \text{cm}^{-1}$	Absorption coefficient for oxygen on line 2
k_w	$\text{m}^3 \text{g}^{-1} \text{cm}^{-1}$	Absorption coefficient for water vapor
LE	W m^{-2}	Latent heat flux
L_v	J g^{-1}	Latent heat of vaporization
LV	J g^{-1}	Latent heat of vaporization
M_a	g mol^{-1}	(32) molecular weight of oxygen
OCLE	W m^{-2}	Oxygen correction on latent heat flux
OCSD	g m^{-3}	Oxygen correction on variance of water vapor density
P	kPa	Atmospheric pressure
q	kg kg^{-1}	Specific humidity
Q	kg kg^{-1}	Specific humidity
R	$\text{J mol}^{-1} \text{K}^{-1}$	(8.31) universal gas constant
RA	kg m^{-3}	Density of moist air
RD	kg m^{-3}	Density of dry air
RH	%	Relative humidity
R_n	W m^{-2}	Net radiation
R_v	$\text{J kg}^{-1} \text{K}^{-1}$	Gas constant for water vapor
S	W m^{-2}	Soil storage term
SDR	g m^{-3}	Standard deviation of water vapor density
T'	C	Instantaneous deviation of air temperature from the mean
TA	K	Air temperature
V_h	mV	Signal voltage from the krypton hygrometer
V_{o1}	mV	Signal voltage for oxygen on line 1
V_{o2}	mV	Signal voltage for oxygen on line 2
W	kg kg^{-1}	Soil water content on a mass basis
w'	m s^{-1}	Instantaneous deviation of vertical wind from the mean
x	cm	Krypton hygrometer path length
z	m	Height
z_{om}	m	Roughness length for momentum

APPENDIX E. REFERENCES

- Brutsaert, W.: 1982, *Evaporation into the Atmosphere*, D. Reidel Publishing Co., Dordrecht, Holland, 300.
- Buck, A. L.: 1976, "The Variable-Path Lyman-Alpha Hygrometer and its Operating Characteristics," *Bull. Amer. Meteorol. Soc.*, **57**, 1113-1118.
- Campbell, G. S., and Tanner, B. D.: 1985, "A Krypton Hygrometer for Measurement of Atmospheric Water Vapor Concentration." *Moisture and Humidity*, ISA, Research Triangle Park, North Carolina.
- Dyer, A. J. and Pruitt, W. O.: 1962, "Eddy Flux Measurements Over a Small Irrigated Area", *J. Applied Meteorol.*, **1**, 471-473.
- Gash, J. H. C.: 1986, "A Note on Estimating the Effect of a Limited Fetch On Micrometeorological Evaporation Measurements", *Boundary-Layer Meteorol.*, **35**, 409-413.
- Goff, J.A. and Gratch, S.: 1946, "Low-Pressure Properties of Water from -160° to 212°F", *Trans. Amer. Soc. Heat. Vent. Eng.*, **51**, 125-164.
- Hanks, R. J. and Ashcroft, G. L.: 1980, *Applied Soil Physics: Soil Water and Temperature Application*, Springer-Verlag, New York.
- Lowe, P. R.: 1977, "An Approximating Polynomial for the Computation of Saturation Vapor Pressure", *J. Applied Meteo.*, **16**, 100-103.
- Panofsky, H. A. and Dutton, J. A.: 1984, *Atmospheric Turbulence: Models and Methods for Engineering Applications*, John Wiley and Sons, New York.
- Schuepp, P. H., Leclerc, M. Y., MacPherson, J. I., and Desjardins, R. L.: 1990, "Footprint Prediction of Scalar Fluxes from Analytical Solutions of the Diffusion Equation", *Boundary-Layer Meteorol.*, **50**, 355-373.
- Shuttleworth, W. J.: 1992, "Evaporation" (Chapter 4), in Maidment (ed), *Handbook of Hydrology*, Mc Graw-Hill, New York, 4.1-4.53.
- Stull, R. B.: 1988, *An Introduction to Boundary Layer Meteorology*, Kluwer Academic Publishers, Boston.
- Tanner, B. D.: 1988, "Use Requirements for Bowen Ratio and Eddy Correlation Determination of Evapotranspiration", *Proceedings of the 1988 Specialty Conference of the Irrigation and Drainage Division, ASCE*, Lincoln, Nebraska, 19-21 July 1988.
- Tanner, C. B.: 1979, "Temperature: Critique I", in T. W. Tibbits and T. T. Kozolowski (ed.), *Controlled Environmental Guidelines for Plant Research*, Academic Press, New York.
- Webb, E.K., Pearman, G. I., and Leuning, R.: 1980, "Correction of Flux Measurement for Density Effects due to Heat and Water Vapor Transfer", *Quart. J. Roy. Meteor. Soc.*, **106**, 85-100.
- Weiss, A.: 1977, "Algorithms for the Calculation of Moist Air Properties on a Hand Calculator", *Amer. Soc. Ag. Eng.* **20**, 1133-1136.

Campbell Scientific Companies

Campbell Scientific, Inc. (CSI)

815 West 1800 North
Logan, Utah 84321
UNITED STATES
www.campbellsci.com
info@campbellsci.com

Campbell Scientific Africa Pty. Ltd. (CSAf)

PO Box 2450
Somerset West 7129
SOUTH AFRICA
www.csafrica.co.za
sales@csafrica.co.za

Campbell Scientific Australia Pty. Ltd. (CSA)

PO Box 444
Thuringowa Central
QLD 4812 AUSTRALIA
www.campbellsci.com.au
info@campbellsci.com.au

Campbell Scientific do Brazil Ltda. (CSB)

Rua Luisa Crapsi Orsi, 15 Butantã
CEP: 005543-000 São Paulo SP BRAZIL
www.campbellsci.com.br
suporte@campbellsci.com.br

Campbell Scientific Canada Corp. (CSC)

11564 - 149th Street NW
Edmonton, Alberta T5M 1W7
CANADA
www.campbellsci.ca
dataloggers@campbellsci.ca

Campbell Scientific Ltd. (CSL)

Campbell Park
80 Hathern Road
Shepshed, Loughborough LE12 9GX
UNITED KINGDOM
www.campbellsci.co.uk
sales@campbellsci.co.uk

Campbell Scientific Ltd. (France)

Miniparc du Verger - Bat. H
1, rue de Terre Neuve - Les Ulis
91967 COURTABOEUF CEDEX
FRANCE
www.campbellsci.fr
campbell.scientific@wanadoo.fr

Campbell Scientific Spain, S. L.

Psg. Font 14, local 8
08013 Barcelona
SPAIN
www.campbellsci.es
info@campbellsci.es